

Accu-Screw™ - Holders & Receivers For Davenports, Brown & Sharp or Swiss Style Machines

Quick-Change Drilling For Screw Machines

- Designed for use on Davenport , Brown & Sharpe and Swiss Style Machines
- 5-10 Second tool change with no tools needed for insertion
- Preset drills offline for maximum accuracy and minimum downtime
- Uses ER single angle collets - dramatic improvement over double angle collets
- Repeatable - .0005 TIR at 4"
- Set tool block or receiver one time and change tools with no additional setup time
- Your first part is a good part! – reduce scrap, eliminate setups, save time & money

Quik-Screw™ Drill Holder

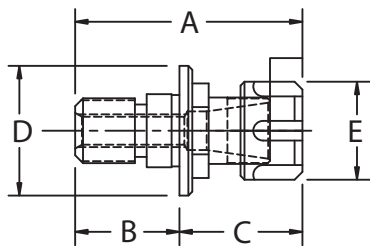

Part #	Collet	A	B	C	D	E	Collet Nut
A-6985-000	ER 11	1.772	0.800	0.972	0.875	0.748	A-4139-211
A-6986-000	ER 16	2.237	0.800	1.437	0.875	0.748	A-4141-400
A-6989-000	ER 11	1.772	0.800	0.972	1.000	0.748	A-4139-211
A-6990-000	ER 16	2.237	0.800	1.437	1.000	1.103	A-4141-400
A-6993-000	ER 16	2.562	1.125	1.437	1.250	1.103	A-4141-400
A-6995-000	ER 25	2.750	1.125	1.625	1.250	1.600	A-4143-325

- Holder has a positive stop screw and is coolant thru capable.
- Preset offline and insert into receiver (see below) using no tools for insertion, and flat wrench on hex for removal.
- ER single angle collets are far more accurate than double angle collets, producing better parts and longer tool life.

Quik-Screw™ Receiver

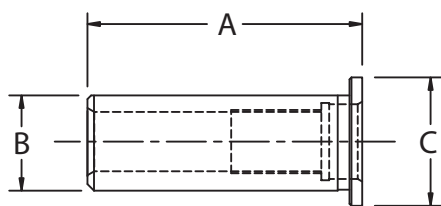

Part #	Quik-Screw#	A	B	C
A-6970-000	A-6985-000	2.100	0.625	0.875
	A-6986-000	2.100	0.625	0.875
A-6975-000	A-6989-000	2.100	0.750	1.000
	A-6990-000	2.100	0.750	1.000
A-6980-000	A-6993-000	3.100	1.000	1.250
	A-6995-000	3.100	1.000	1.250

- Receiver is positioned and centered in machine tool block for initial tool setup
- Holders are preset offline eliminating additional downtime

Accu-Screw™ - Flange Mounts

For Davenports, Brown & Sharp or Swiss Style Machines

Quick-Change Drilling For Screw Machines

Quik Screw™ Adjustable Flange Receiver

- Designed for use on Davenport , Brown & Sharpe and Swiss Style Machines using the Quik-Screw™ Drill Holder
- Allows for precision correction on misalignment between spindle and turret centerlines by adjusting face to face alignment with set screws
- Set it once and periodically recheck - no need to reset with every tool change
- Coolant thru capability
- Ideal system for turret lathes and most automatics

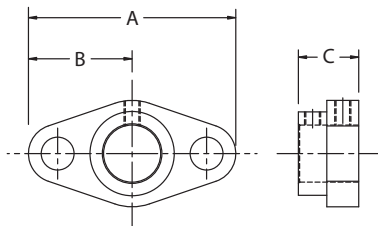

Quik-Screw™ Adjustable Flange(AF)

Part #	Quik-Screw#	Range	A	B	C
A-6950-000	A-6985-000	1/32-17/64	2.000	1.000	0.710
	A-6986-000	1/32-3/8	2.000	1.000	0.710
A-6955-000	A-6989-000	1/32-17/64	2.312	1.157	1.000
	A-6990-000	1/32-3/8	2.312	1.157	1.000
A-6960-000	A-6993-000	1/32-3/8	3.125	1.563	1.250
	A-6995-000	1/16-5/8	3.125	1.563	1.250

Will mount to Somma Adjustable Flange Holder - Page 83 Somma 2000

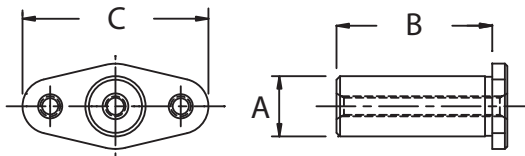

Quik-Screw™ Adjustable Flange Mount (AF)

Part #	AF Part #	A	B	C
A-6950-625	A-6950-000	0.625	1.125	2.000
A-6950-750	A-6950-000	0.750	2.000	2.000
A-6955-750	A-6855-000	0.750	1.937	2.312
A-6960-750	A-6960-000	0.750	1.406	3.125
A-6960-100	A-6960-000	1.000	2.937	3.125

ACCURATE, REPEATABLE AND COST EFFECTIVE!



Accu-Screw™ - Receivers & Holders For Acme-Gridley, New Britain & Large Block Machines

Quick-Change Drilling For Screw Machines

Accu-Screw™ Receivers & Holders

- Designed for use on Acme-Gridley, New Britain and other Large Block Machines
- 5-10 second tool change with no tools needed for insertion
- Preset drills offline for maximum accuracy and minimum downtime
- Set Receiver in tool block one time and quick-change tools with no additional setup time
- Repeatable - .0005 TIR at 4"

Accu-Screw™ Receivers

- Insert Accu-Screw holder with 1/4 turn of quick-change locking adapter
- Coolant capable with 1/4 -18 or 1/2 -14 NPT connection

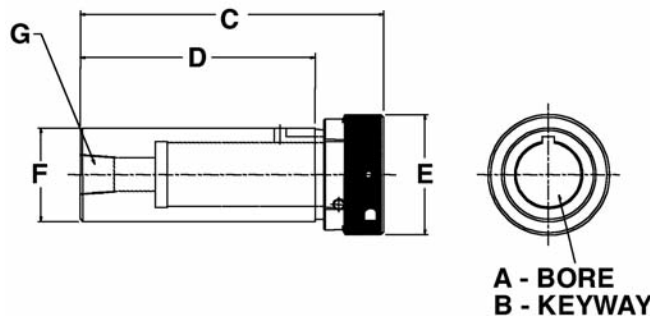

Part #	A	B	C	D	E	F	G
A-6920-000	5/8	5/32	5.43	4.00	1.562	1.00	1/4-18 NPT
A-6925-000	3/4	5/32	5.43	4.00	1.770	1.25	1/2-14-NPT
A-6930-000	3/4	5/32	5.43	4.00	1.770	1.50	1/2-14-NPT
A-6935-000	1-1/16	3/16	5.43	4.00	2.190	1.50	1/2-14-NPT
A-6940-000	1-3/8	1/4	6.43	5.00	2.565	2.00	1/2-14-NPT

*Additional shank O.D. and I.D.'s available upon request

Accu-Screw™ Holders

- Uses ER Single Angle Collets for Increased Accuracy vs. Double Angle Collets
- Your First Part is a good part! – reduce scrap, eliminate setups, save time & money
- Internal pre set stop screw standard, Posi-Drive assembly available upon request

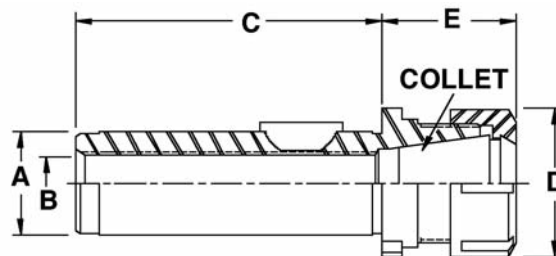

Part #	Shank Dia. A	Collet Series	Collet Range	Adjustment Screw	Max Dia. Thru Shank B	Shank Length C	Collet NutNose D		PRJCTN E
							Max O.D.	Hex Size	
A-6900-000	5/8	ER-11	.0019 to .276	5/16-24 LH	.250	1.125	.630	.433	1.35
A-6905-000	3/4	ER-16	.019 to .394	7/16-20 LH	.375	1.500	1.10	N/A	1.80
A-6910-000	1-1/16	ER-32	.079 to .787	3/4-16 LH	.656	1.812	1.97	N/A	1.75
A-6915-000	1-3/8	ER-32	.079 to .787	13/16-20 LH	.750	2.000	1.97	N/A	1.75

***ADDITIONAL SHANK O.D. AND COLLET SIZES AVAILABLE UPON REQUEST**

